

TDG50Plus LINE BORING

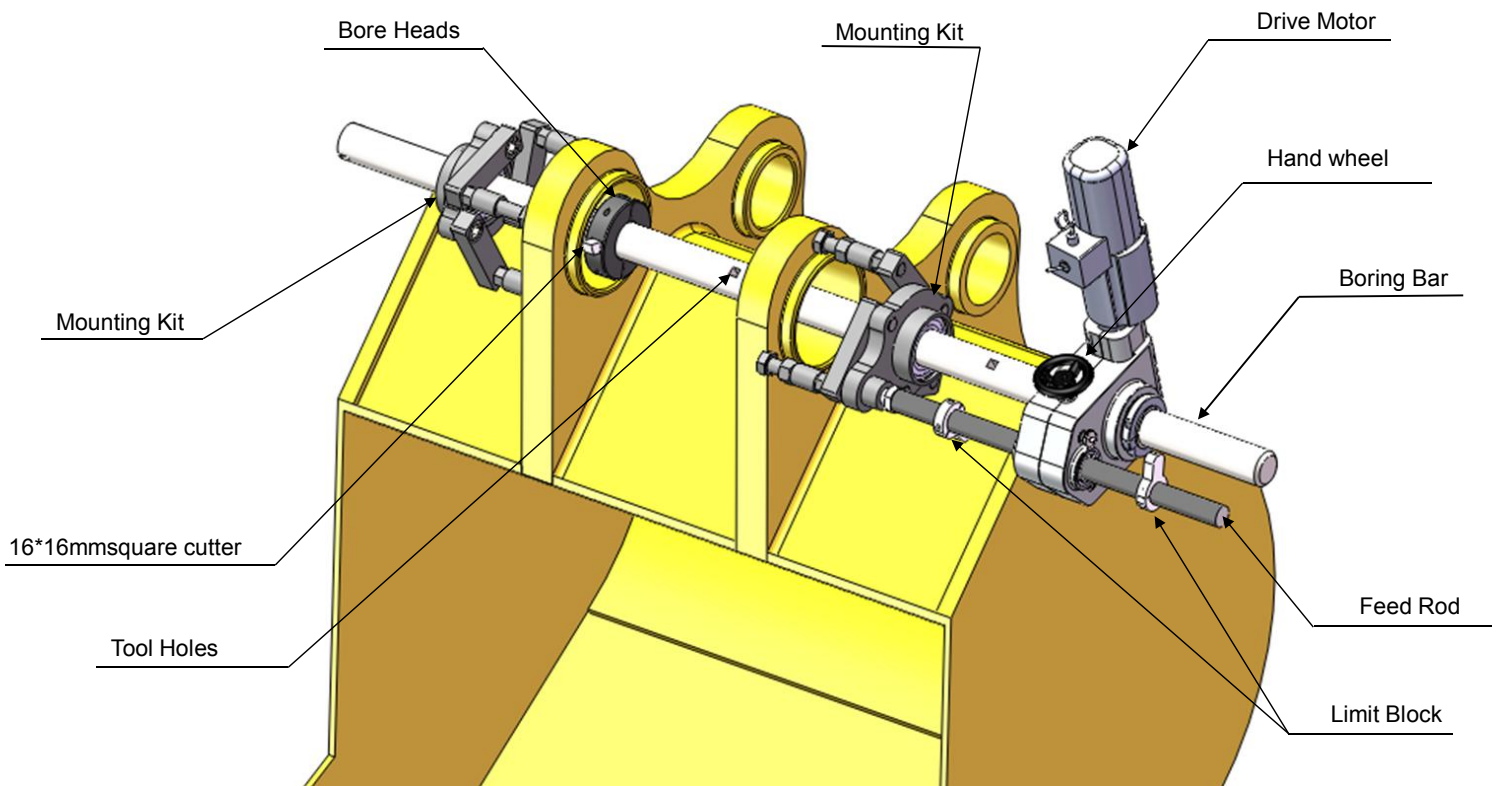

Functions

- Conventional Boring
- Line Boring
- Drilling, Trepanning
- Threading
- Facing
- Grooving

Typical Applications

- Heavy equipment repair
- Stern tube boring
- Wicket gate repair on dams
- Bridge building/re-building
- Turbine coupling boring
- Bearing seat repair
- Engine block repair
- Presses repair
- Valve body repair
- Pump body boring
- Large fab bore alignment

DRIVE GEARBOX / MOTOR

Drive Gearbox

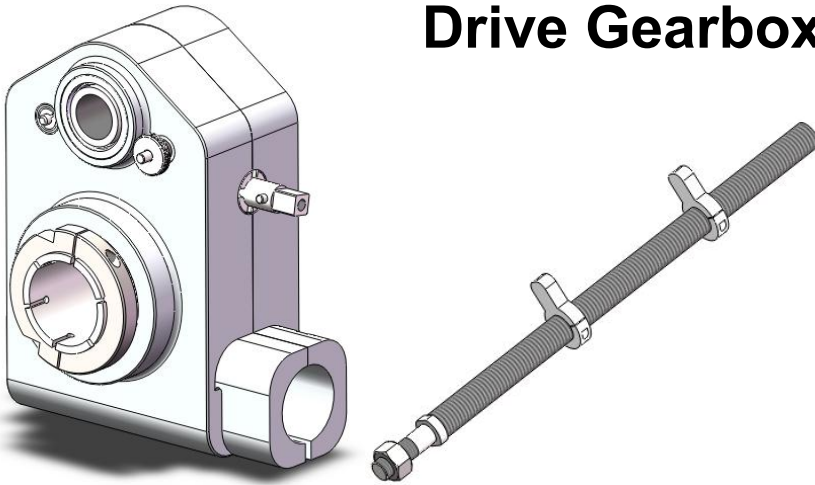

- Boring stroke:280mm
 - Mechanical feed, feed rate per revolution:0-0.5mm/rev
 - Provide a 3:1 gear reduction ratio for increased torque.
 - Adjustable limit block
 - Weight: 9 kg
-

Drive Motor



- Eibenstock, made in Germany
- Single phase,110V/230V, 50/60Hz, 1800W
- 2 bar speeds, 0-83 &83-150rpm
- Weight: 4.6 kg

BORING BAR / MOUNTING KIT / RAPID CENTERING SYSTEM

BORING BAR



Chrome plated Boring Bar, $\text{Ø}50 \times 1820\text{mm}$, boring diameter: $\text{Ø}55\text{-}350\text{mm}$ Tool holes spaced every 200mm, tool holes: $16 \times 16\text{mm}$



Chrome plated Boring Bar, $\text{Ø}35 \times 1200\text{mm}$, boring diameter: $\text{Ø}38\text{-}120\text{mm}$ Tool holes spaced every 120mm, tool holes: $12 \times 12\text{mm}$

SLEEVE SET

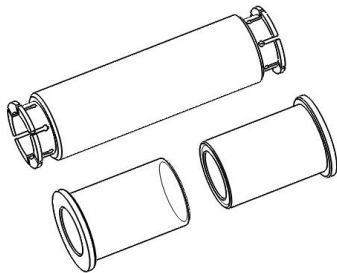

- Fit to $\text{Ø}50\text{mm}$ bar
- Sleeve Set : 1 Drive Gearbox sleeves

2 Bearing sleeves

BORE HEADS

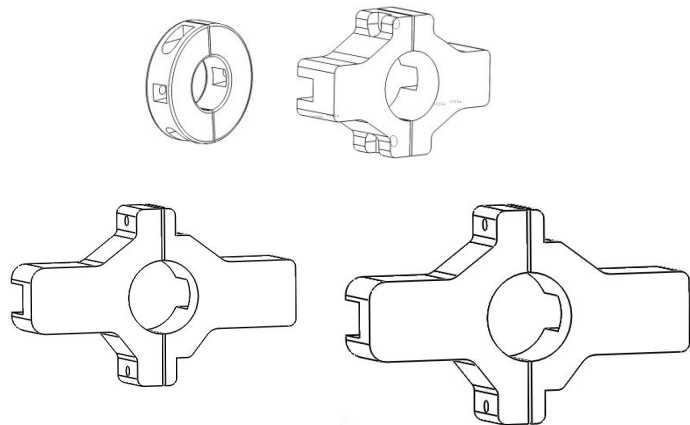

- Fit to $\text{Ø}50\text{mm}$ bar
- $16 \times 16\text{mm}$ square cutter
- Boring diameter: $\text{Ø}120\text{-}165\text{mm} \setminus \text{Ø}150\text{-}230\text{mm}$
 $\text{Ø}200\text{-}280\text{mm} \setminus \text{Ø}250\text{-}350\text{mm}$

MOUNTING KIT

- Fit for boring from 55-350mm
- Support of machines complete with brackets to knee

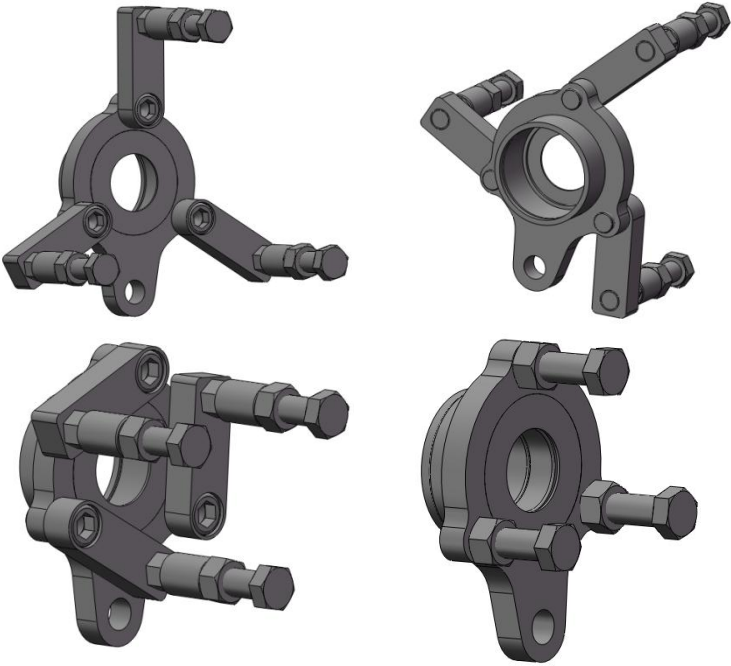

FACING HEAD

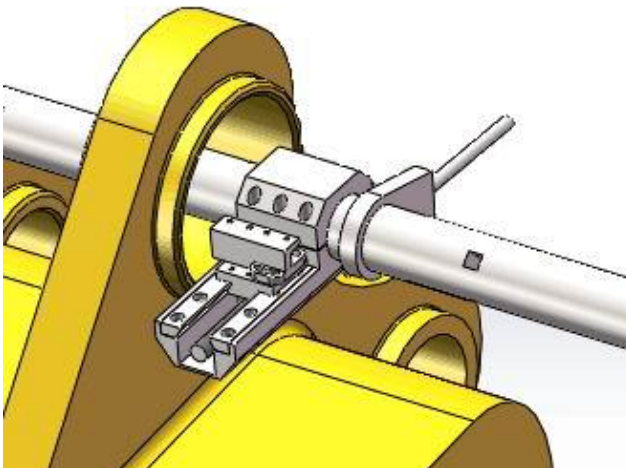

- Facing diameter:80-380mm
- Optional part(if need, please choose)

RAPID CENTERING SYSTEM

- Three magnet mounting
- 2 pcs for centering boring bar .
- Max control range:300mm



STANDARD EQUIPMENT

TDG50 Plus

1	Boring Bar : Ø50*1820mm	1 PCS
2	Boring Bar : Ø35*1200mm	1 PCS
3	Drive Gearbox	1 SET
4	Hand wheel	1 PCS
5	Feed Rod	1 PCS
6	Limit block	2 PCS
7	Screw locking nut	1 PCS
8	Power Unit: 110V/230V, 50/60Hz, 1800W	1 PCS
9	Mounting Options	2 SET
10	Reduction Sleeve	3 PCS
11	Rapid centering system	2 SET
12	Bore Heads	4 PCS
13	Bore measuring tool: Digital Calipers,50mm bar	1 PCS
14	16*16mm square cutter	1 PCS
15	12*12mm square cutter	1 PCS
16	Tool Pack	1 SET
17	Packing case	2 PCS